

E-Lock

Operation Manual

Function

- The e-lock can be opened remotely by mobile/web application/SMS or with mechanical key.
- Suitable for commercial applications.
- Sturdy construction and high quality manufacturing ensures long lasting performance.

Installation

Fix the e-lock and the deadbolt holder on the surface of the tanker. Please ensure to keep about 5mm distance between the lock body and the deadbolt holder as shown in the diagram below:

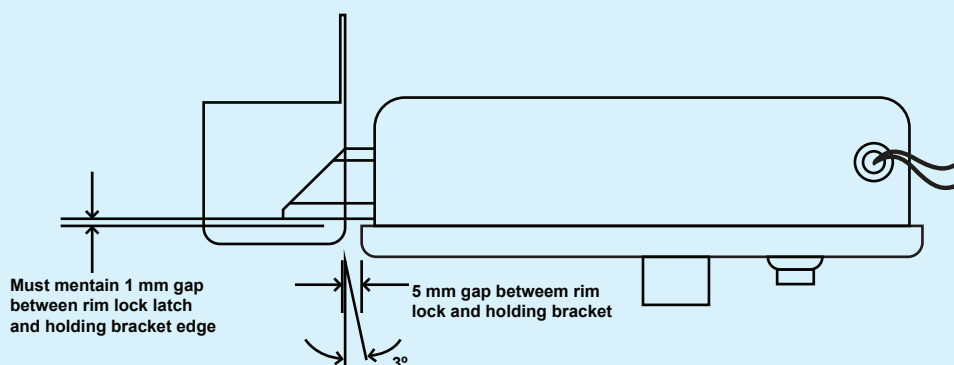

Although the lock is designed to suit most common applications, adjustment of loading spring tension might be required depending on the type of shutter and closing force. If the shutter is not getting locked, then loosen the tension by turning the hexagon nut (using 12 No. wrench). If the shutter is getting closed loosely, then increase the tension by turning the hexagon nut to make it work perfectly.

hexagon nut

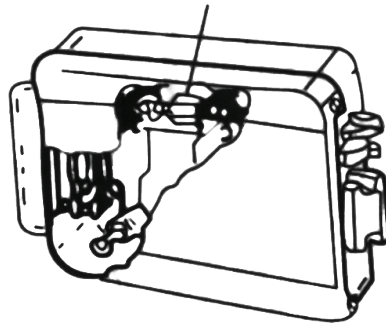

Section mm ²	Diameter of line ϕ	Cable length m
0.3	0.6	8
0.5	0.8	15
1	1.2	25
1.5	1.4	40
2.5	1.8	60

The e-lock operates on 9 V – 12 V DC @ 1 A. Recommended wiring specifications corresponding to length of cable is mentioned above.